

V207 L / V208 T Port , Direct Mount Pad, BSP Threaded End 3 Way Ball Valves

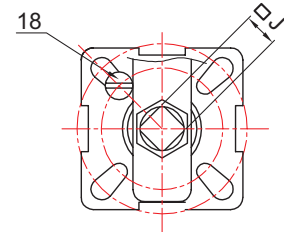
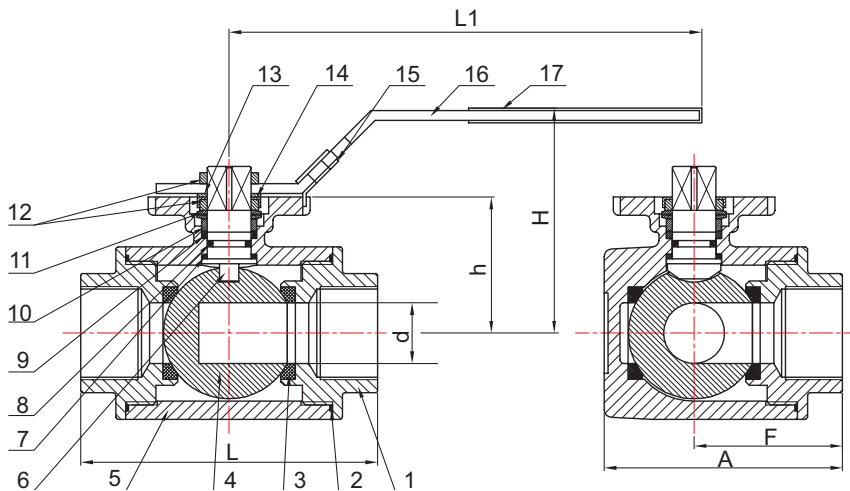

ISO5211 Top Flange

Material List

No	Description	Material	Quantity
1	Cap	AISI316	3
2	Body Gasket	PTFE	3
3	Ball Seat	PTFE	4
4	Ball	AISI316	1
5	Body	AISI316	2
6	Stem	AISI316	1
7	Thrust Washer	PTFE	1
8	O-Ring	Viton	1
9	Stem Packing	PTFE	1
10	Gland Nut	AISI316	1
11	Belleville Washer	AISI301	1
12	Nut	AISI304	1
13	Washer	AISI301	1
14	Locking Washer	AISI304	1
15	Locking Device	AISI304	1
16	Handle	AISI116	1
17	Handle Cover	Plastic	1
18	Stop Pin	AISI304	1

Port Plan

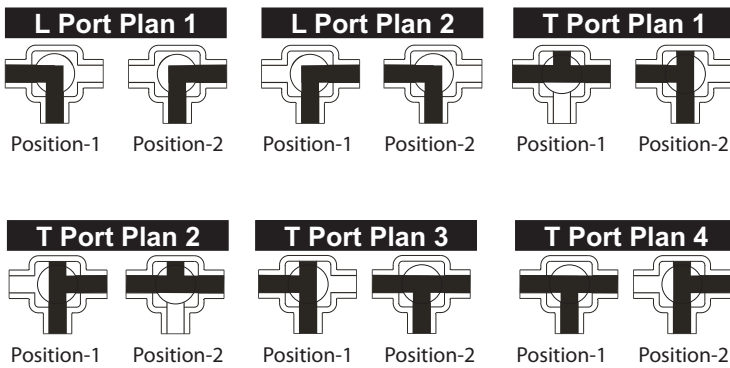

Dimensions (mm)

Size (DN)	d	L	H	H1	F	A	J	ISO5211 Top Flange	Torque (N.m)	Weight (Kg)
1/4"	9,5	75	66	130	37,5	57,5	9	F03/F04	8	0,70
3/8"	11	75	66	130	37,5	57,5	9	F03/F04	8	0,67
1/2"	12	75	66	130	37,5	57,5	9	F03/F04	8	0,73
3/4"	15	85	72	161	42,5	65,5	11	F04/F05	9	0,94
1"	20	100	77	161	50	79	11	F04/F05	15	1,38
1-1/4"	25	122	92	203	61	97	14	F05/F07	20	2,89
1-1/2"	32	131	96	203	65,5	106,5	14	F05/F07	30	3,60
2"	40	158	107	203	79	129	14	F05/F07	45	6,21
2-1/2"	49	178	185	254	89	145	17	F07/F10	50	8,72
3"	69	202	147	254	101	167	17	F07/F10	80	12,81
4"	75	246	169	310	123	205	17	F07/F10	110	21,60

